

HORIBA

Process & Environmental

AIR POLLUTION MONITOR **AP-370 Series**

Type approved by European agencies and US.EPA



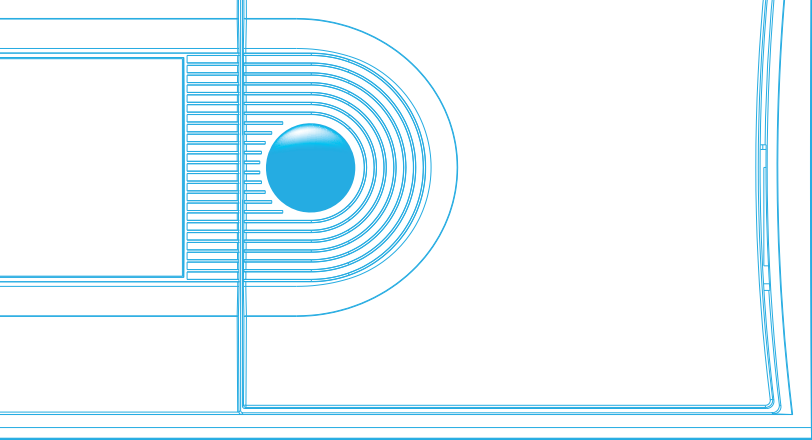

These highly sensitive analyzers give precise, reliable measurements and are surprisingly easy to maintain.

Features

Automatic calibration

Troublesome calibration procedures have been reduced to the push of a function key. At the Auto-Interval Calibration (AIC) menu you can set the start time, the start range, and the interval for the automatic calibration. The system clock and calendar then assure that your calibration instructions are executed precisely. To make things even easier, remote auto-calibration can also be done from your own computer, via the monitor's RS-232C serial port (optional).

Auto-range function

An auto-range function that automatically switches to the range best suited to the object gas concentration for both momentary and average values is included as a standard feature. As an option, even when randomly set to any range (within 10 times the range ratio), the auto-range function can still be used. Switching over from auto-range to manual-range is a simple task.

Selective data output

For each component measured, the system provides four types of data: momentary values, integrated values, moving averages, and simple averages. Any two of these data may be output. Simultaneously to any two external devices. The time-span for both average and integrated values may be specified (i.e., when the momentary value has not been selected). With the simple average values, three different time settings can be specified.

Storing data in memory

Four different values may be stored in memory: three simple averages and the integrated value.

For example:

- ▶ Average value #1 (3 min) → 1,000 data sets
- ▶ Average value #2 (30 min) → 1,000 data sets
- ▶ Average value #3 (3 h) → 100 data sets
- ▶ Integrated value (1 h) → 1,000 data sets

Network Communications (option)

Serial communication is available through RS-232C serial port connected on the rear panel. The serial port makes analyzer data available using HORIBA's proprietary serial communication protocol, and can be easily converted to RS-485 for network data collection. Ethernet communication is available through an optional port using TCP/IP protocol.

ambient air pollution monitors
measurements, yet they are
maintain.

AIR POLLUTION MONITOR **AP-370** Series

■ **Memory card for data management** (option)

An available CompactFlash®(CF) can save average or integrated value, and read and collect data for off-line analysis.

With the CF it is possible to conveniently use the analyzer in a stand-alone mode.

■ **Readout view, concentration and mass**

The front panel can display the readout all that is needed concentration (ppm or ppb) and mass (mg/m^3 or $\mu\text{g}/\text{m}^3$).

(Not available on Model APHA-370, where CH_4 values are displayed as ppm, NMHC and THC as ppmC.)

■ **Pressure-compensation**

Automatic compensation for ambient pressure assures reliable data regardless of the weather or the monitor's location.

■ **Easy-to-read, 320 × 240 dot LCD display with touch panel screen.**

The adoption of full graphic LCD for the touch screen offers a large, easy-to-use display and user friendly, interactive operation. This user interface facilitates maintenance with displays such as the graph of lamp intensity (applicable for model APOA-370 and APSA-370 only), remaining time before replacement of pumps, valves, source lamp and converters. It also allows you to save average value, data, integrated value alarm history and calibration history.

■ **Minimal influence from interference components and ambient temperature**

These monitors use Horiba's innovative detection technology and sampling method for outstanding sensitivity. The influence from interference components is minimal and results are very stable over long periods of measurement.

■ **Input/output via RS-232C port** (option)

The system's RS-232C serial port can be used to transmit measured values, alarms, and other data to remote equipment. It can also be used to input changes to parameter settings and other data.

■ **At last—a small, compact system**

A small, light-weight unit for each component to be measured fits neatly into a 19-inch rack. This makes it easy to up-grade your system in the future. This new design offers great savings in valuable lab space.

COMPACTFLASH is a registered trademark or trademark of SanDisc Corporation in the United States and other countries.



Ambient CO Monitor APMA-370



According to EN14626 and VDI 4202/4203
TUEV Bericht 936/21204643B 05. Jan. 2006 U. S. EPA REFERENCE Equivalent Number RFCA-0506-158

Features

The cross flow modulation type, infrared-absorption technology eliminates the need for adjusting optical alignment.
For the user, this means very stable and sensitive (5 ppm F.S.) measurements.

The APMA-370 uses an AS type (antishock) interference-compensating detector, and a purified reference gas. The reference gas is generated by purging the sample through an oxidation process, where an oxidizing catalyst burns the CO to CO₂. These features eliminate interference from other elements, resulting in highly accurate measurements.

The APMA-370 does not use such components as reflecting mirrors, that attract foreign matter. This means the optical bench stays clean assuring you of stable results over long periods of time.

Principle

Cross flow modulation, Infrared (NDIR) absorption technology

Conventional technology uses an optical chopper to obtain modulation signals. Instead, the APMA-370 uses solenoid valve cross flow modulation. Fixed amounts of the sample gas and the reference gas are injected alternately into the measurement cell. With the cross flow modulation method, if the same gas is used for both the sample gas and the reference gas (e.g., zero gas could be used for both), no modulation signal will be generated. This has the great advantage that, in principle, when analyzing minute amounts of gas there is no generation of zero-drift. An additional advantage is that the elimination of rotary sectors precludes the need for optical adjustment. These features assure greatly improved stability over long periods of measurement. A further improvement is that in the front chamber of the detector, the measurable components, including interference components, are detected; in the rear chamber, only interference components are detected. By means of subtraction processing, the actual signal obtained is one that has very little interference.

Specifications

Principle: Cross flow modulation, non-dispersive infrared (NDIR) absorption technology

Application: CO in ambient air

Range: Standard ranges: 0-10/20/50/100 ppm; 0-5/10/20/50 ppm; auto range ~ manual range selectable; can be operated by remote switching.
Optional (measurable) ranges: 4 ranges selectable from 0-100 ppm, within 10 times range ratio; auto range ~ manual range selectable; can be operated by remote switching.

Lower detectable limit: 0.02 ppm (3 sigma)

Repeatability: ±1.0% of F.S.

Linearity: ±1.0% of F.S.

Zero drift: <LDL/day at lowest range
<0.2 ppm/week at lowest range

Span drift: <LDL/day at lowest range
±1.0% F.S./week

Response time (T₉₀): Within 50 sec at lowest range

Sample gas flow rate: Approx. 1.5L/min

Indication: Measured value, range, alarm, maintenance screen

Alarms: During AIC, zero calibration error, span calibration error, temperature error in catalyzer, etc.

On-screen messages are available in four languages: English, German, French, and Japanese.

Input/output: • 0-1 V/0-10 V/4-20 mA, to be specified (2 systems: either (1) momentary value and integrated or (2) moving average value) • Contact input/output • RS-232C (option)

Ambient temperature: 5-40 °C

Power: 100/110/115/120/220/230/240 VAC, 50/60 Hz (to be specified)

Dimensions: 430(W)×550(D)×221(H) mm

Mass: Approx. 16 kg,

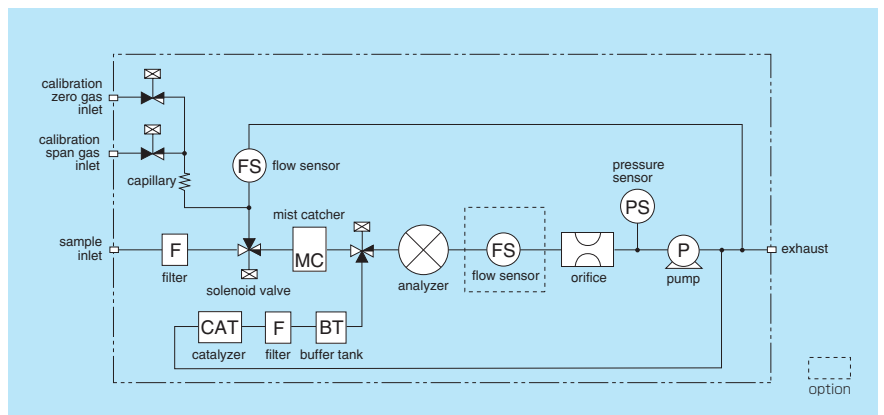



Ambient SO₂ Monitor APSA-370



According to EN14212 and VDI 4202/4203

TUEV Bericht 936/21204643D 07. Jul. 2006 U. S. EPA REFERENCE Equivalent Number EQSA-0506-159

Features

The APSA-370 uses an innovative detector and a new optical system for low background, high sensitivity (0.05 ppm F.S.), and greatly improved stability.

The fluorescent chamber design gives measurements with minimum influence from moisture.

The unit has built-in aromatic hydrocarbon cutter with a selective transmission membrane. This reduces the influence of interference components. Coupled with Horiba's unique flow-path, it also makes it possible to extend the working life of the cutter and to take measurements effects of sample flow variations.

In comparison with the FPD method, the APSA-370 design is (1) highly selective for SO₂, (2) requires no supplemental gas, and (3) gives linear output.

Compensation for the lamp's luminous energy decline guarantees prolonged calibration stability.

The sample inlet has a built-in PTFE filter.

Principle

UV fluorescence

The UV fluorescence method operates on the principle that when the SO₂ molecules contained in the sample gas are excited by ultraviolet radiation they emit a characteristic fluorescence in the range of 220-420 nm. This fluorescence is measured and the SO₂ concentration is obtained from changes in the intensity of the fluorescence.

The reactive mechanism is

- (1) $SO_2 + h\nu_1 \rightarrow SO_2^*$
- (2) $SO_2^* \rightarrow SO_2 + h\nu_2$
- (3) $SO_2^* \rightarrow SO + (O)$
- (4) $SO_2^* + M \rightarrow SO_2 + M$

Here, (1) shows the excited state of the SO₂ molecules that have absorbed the amount of energy $h\nu_1$ by ultraviolet radiation. (2) shows the amount of energy, $h\nu_2$ emitted by the excited molecules as they return to the ground state. (3) shows the decomposition by the light emitted from the excited molecules. (4) shows the quenching, i.e., the energy lost by the excited molecules colliding with other molecules. The APSA-370 uses an Xe lamp as the light source, and the fluorescent chamber design minimizes scattered light. The optical system has been carefully designed with low background light, making it possible to take measurements with a highly stable zero point. In addition, a reference detector monitors any fluctuation in the intensity of the light source. This allows the unit to calibrate itself automatically for sensitivity, resulting in greater span stability.

Specifications

Principle: UV fluorescence (UVF)

Application: SO₂ in ambient air

Range: Standard ranges: 0-0.05/0.1/0.2/0.5 ppm; auto range ~ manual range selectable; can be operated by remote switching.

Optional (measurable) ranges: 4 ranges selectable from 0-10 ppm, within 10 times range ratio; auto range ~ manual range selectable; can be operated by remote switching.

Lower detectable limit: 0.5 ppb(3 sigma)

Repeatability: ±1.0% of F.S.

Linearity: ±1.0% of F.S.

Zero drift: <LDL/day at lowest range
<LDL/week at lowest range

Span drift: <LDL/day at lowest range
<LDL/week at lowest range

Response time (T₉₀): Within 120 sec at lowest range

Sample gas flow rate: Approx. 0.7L/min

Indication: Measured value, range, alarm, maintenance screen

Alarms: During AIC, zero calibration error, span calibration error, temperature error in catalyzer, etc.

On-screen messages are available in four languages: English, German, French, and Japanese.

Input/output: • 0-1 V/0-10 V/4-20 mA, to be specified (2 systems: either (1) momentary value and integrated or (2) moving average value) • Contact input/output • RS-232C (option)

Ambient temperature: 5-40 °C

Power: 100/110/115/120/220/230/240 VAC, 50/60 Hz (to be specified)

Dimensions: 430(W)×550(D)×221(H) mm

Mass: Approx. 19 kg,

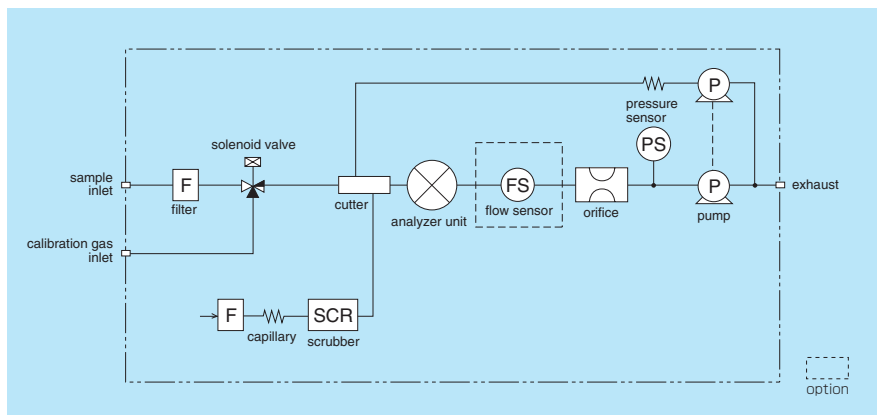



Ambient NOx Monitor APNA-370

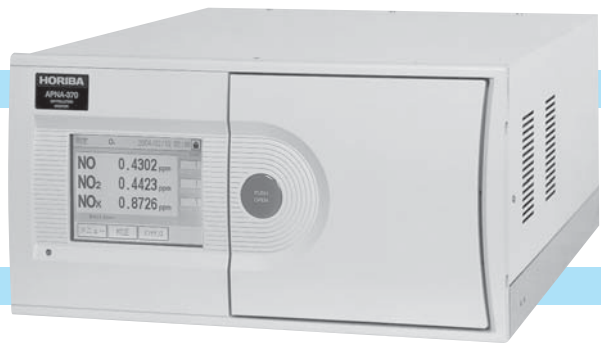

According to EN14211 and VDI 4202/4203
TUEV Bericht 936/21204643C 07. Jul. 2006 U. S. EPA REFERENCE Equivalent Number RFNA-0506-157

Features

The APNA-370 uses a combination of the dual cross flow modulation type chemiluminescence principle and the referential calculation method.

This gives it the advantages of the single-detector method plus the ability to do continuous measurements of NOx, NO, and NO₂. The design gives great stability and extremely high sensitivity (0.1 ppm F.S.)

Standard equipment includes a drier unit with an automatic recycle function to provide dry ambient air as the ozone source. This makes long-term continuous measurements possible.

The detector uses a silicon photodiode sensor to reduce size and prolong working life.

All the necessary features are built right into a single rack-sized unit, including a reference-gas generator, an ozone-source drier unit, an ozone decomposer, and a sampling pump. No supplemental gas is required.

Principle

Cross flow modulation type, reduced pressure chemiluminescence (CLD)

The chemiluminescence method uses the reaction of NO with O₃

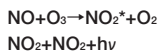

A portion of the NO₂* generated as the result of this reaction becomes NO₂*. As these excited molecules return to the ground state, chemiluminescence is generated in the range of 600 nm to 3,000 nm. The light intensity is in proportion to the concentration of NO molecules and by measuring it we obtain the NO concentration of the sample. A deoxidation converter changes the NO₂ to NO, which is measured. In other words, the NO₂ concentration can be obtained by the difference between (1) the NOx concentration measured when the sample gas is directed through a converter and (2) the NO concentration measured when the gas is not run through the converter.

Specifications

Principle: Cross flow modulation type, reduced pressure chemiluminescence (CLD)

Application: NO₂, NO and NOx in ambient air

Range: Standard ranges: 0-0.1/0.2/0.5/1.0 ppm; auto range ~ manual range selectable; can be operated by remote switching.

Optional (measurable) ranges: 4 ranges selectable from 0-10 ppm, within 10 times range ratio; auto range ~ manual range selectable; can be operated by remote switching.

Lower detectable limit: 0.5 ppb(3 sigma)

Repeatability: ±1.0% of F.S.

Linearity: ±1.0% of F.S.

Zero drift: <LDL/day, at lowest range
±1.0 ppb/week at lowest range

Span drift: <LDL/day at lowest range
±1.5 % of F.S./week

Response time (T₉₀): Within 90 sec at lowest range

Sample gas flow rate: Approx. 0.8L/min

Indication: Measured value, range, alarm, maintenance screen

Alarms: During AIC, zero calibration error, span calibration error, temperature error in converter, etc.

On-screen messages are available in four languages: English, German, French, and Japanese.

Input/output: • 0-1 V/0-10 V/4-20 mA, to be specified (2 systems: either (1) momentary value and integrated or (2) moving average value) • Contact input/output • RS-232C (option)

Ambient temperature: 5-40 °C

Power: 100/110/115/120/220/230/240 VAC, 50/60 Hz (to be specified)

Dimensions: 430(W)×550(D)×221(H) mm

Mass: Approx. 21 kg,

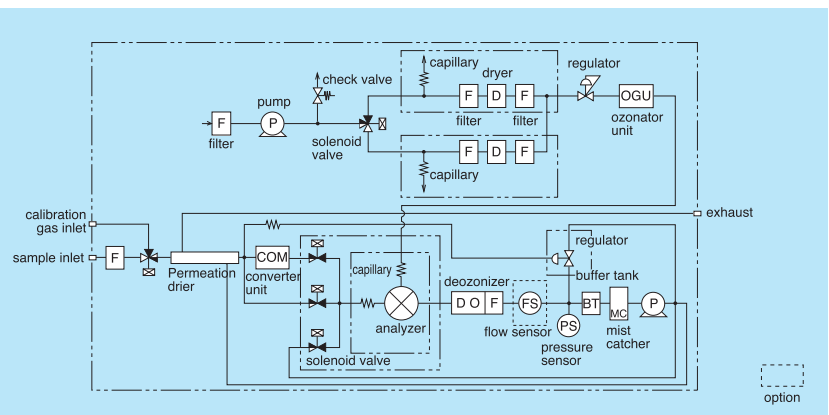



Ambient THC Monitor APHA-370

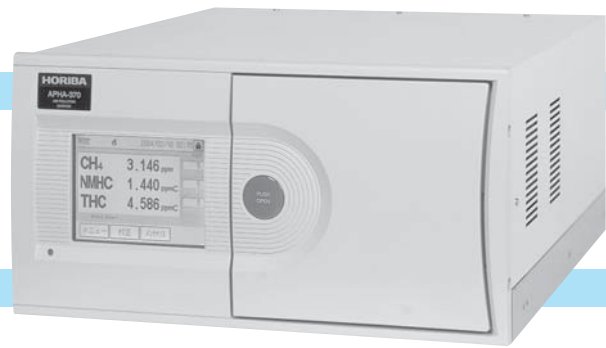

Features

The APHA-370 uses a combination of the flame ionization detection method and selective-combustion. This gives it the advantage of the single-detector method plus the ability to perform continuous measurements, free of zero-drift, for THC, NMHC, and CH₄. The design gives great stability and high sensitivity (0-5 ppm F.S.)

The APHA-370 has a relative-sensitivity correction function for CH₄ and NMHC.

All the necessary features are built right into a single rack-sized instrument, including a catalytic unit for selective combustion (i.e., an NMHC cutter); a catalytic unit for generating reference gas and auxiliary combustion air (standard); and a sampling pump. The only supplemental gas required is H₂.

Principle

Flame ionization detection method (FID) with selective-combustion

The flame ionization detection method (FID) — used in combination with the selective-combustion system — utilizes the ionization that occurs as the result of the high-temperature energy from combustion at the tip of the burner jet when organic carbon compounds are introduced into the hydrogen flame. The hydrogen flame is located between two electrodes.

When an electrical voltage is applied across these electrodes a minute ion current proportional to the hydrocarbon concentration is produced. This current is monitored by a low leakage amplifier, giving a voltage readout for THC. To measure CH₄ the sample gas is passed through the selective catalytic combustion unit (the NMHC cutter), which oxidizes NMHC without oxidizing CH₄. This is shown as *A* below. *B* represents the THC concentration measured without passing the gas through the NMHC cutter. Thus *B* - *A* will give the concentration of NMHC. The final concentration value is calculated using a relative-sensitivity correction coefficient, *k*, as shown below.

CH₄ Concentration *A*
 NMHC Concentration *k* (*B* - *A*)
 THC Concentration *A* + *k* (*B* - *A*)

Specifications

Principle: Flame ionization detection (FID) with selective combustion

Application: THC, NMHC, and CH₄ in ambient air

Range: Standard ranges: 0-5/10/20/50 ppmC; auto range ~ manual range selectable; can be operated by remote switching.

Optional (measurable) ranges: 4 ranges selectable from 0-100 ppmC, within 10 times range ratio; auto range ~ manual range selectable; can be operated by remote switching.

Lower detectable limit: 0.022 ppmC(3 sigma)

Repeatability: ±1.0% of F.S.

Linearity: ±1.0% of F.S.

Zero drift: <LDL/day at lowest range
 ±0.05 ppmC/week at lowest range

Span drift: <LDL/day at lowest range
 ±0.5 % F.S./week

Response time (T₉₀): Within 60 sec at lowest range

Sample gas flow rate: Approx. 0.9 L/min

Indication: Measured value, range, alarm, maintenance screen

Alarms: During AIC, zero calibration error, span calibration error, temperature error in zero gas purifier, ignition failure error, etc.

On-screen messages are available in four languages: English, German, French, and Japanese.

Input/output: • 0-1 V/0-10 V/4-20 mA, to be specified (2 systems: either (1) momentary value and integrated or (2) moving average value) • Contact input/output • RS-232C (option)

Ambient temperature: 5-40 °C

Power: 100/110/115/120/220/230/240 VAC, 50/60 Hz (to be specified)

Dimensions: 430(W)×550(D)×221(H) mm

Mass: Approx. 33 kg,

Notes: ppmC is shown as symbol, not as unit.

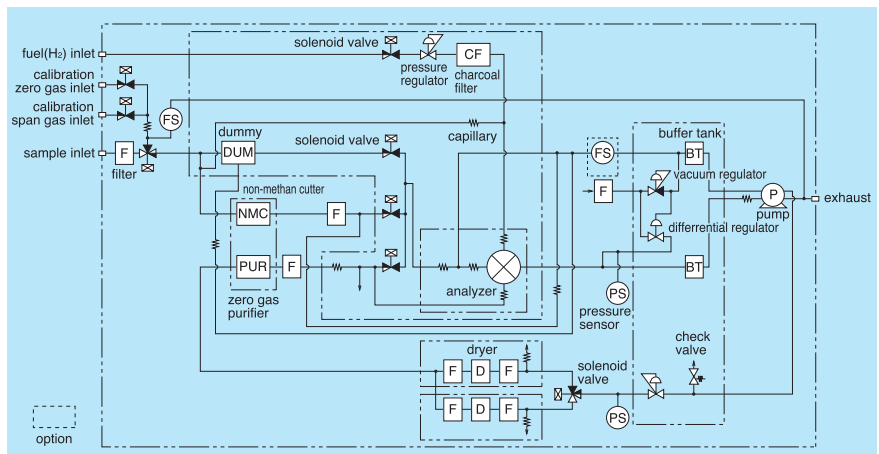



Ambient O₃ Monitor APOA-370



According to EN14625 and VDI 4202/4203

TUEV Bericht 936/21204643A 05. Jan. 2006 U. S. EPA REFERENCE Equivalent Number EQOA-0506-160

Features

The APOA-370 uses the cross flow modulation type, ultra-violet absorption method in conjunction with the comparative calculation method.

This permits continuous measurement with great stability and high sensitivity (0.1 ppm F.S.)

Horiba's innovative heated deozoneizer provides reference gas by decomposing the O₃ found in the sample gas. This has the advantages of (1) reducing the influence from interference, (2) making the monitor insensitive to great changes in moisture content, and (3) prolonging the working life of the monitor.

All gas connections are either PTFE or glass.

Principle

**Cross flow modulation type,
Non dispersive ultra-violet absorption
method (NDUV)**

The ultra-violet absorption method works on the principle that ozone absorbs ultra-violet rays in the area of 254 nm. Measurements are taken from continuous, alternate injections of the sample gas and the reference gas into the measurement cell, controlled by a long-life solenoid valve. The cross flow modulation method is characteristically zero-drift free. A comparative calculation circuit automatically compensates for all fluctuations in the mercury vapor light source and in the detector. This means that, in principle, the APOA-370 makes it possible to carry out zero-span drift free, continuous measurements. In addition, HORIBA'S unique deozoneizer for the comparison gas line is unaffected by interference elements or moisture retention, prolonged, stable measurement is possible.

Specifications

Principle: Cross flow modulation type, Ultra-violet-absorption method (NDUV)

Application: O₃ in ambient air

Range: Standard ranges: 0-0.1/0.2/0.5/1.0 ppm; auto range ~ manual range selectable; can be operated by remote switching.

Optional (measurable) ranges: 4 ranges selectable from 0-10 ppm, within 10 times range ratio; auto range ~ manual range selectable; can be operated by remote switching.

Lower detectable limit: 0.5 ppb(3 sigma)

Repeatability: ±1.0% of F.S.

Linearity: ±1.0% of F.S.

Zero drift: <LDL/day at lowest range

<LDL/week at lowest range

Span drift: <LDL/day at lowest range

<LDL/week at lowest range

Response time (T₉₀): Within 75 sec at lowest range

Sample gas flow rate: Approx. 0.7 L/min

Indication: Measured value, range, alarm, maintenance screen

Alarms: During AIC, zero calibration error, span calibration error, temperature error in ozone separator, light intensity error, etc.

On-screen messages are available in four languages: English, German, French, and Japanese.

Input/output: • 0-1 V/0-10 V/4-20 mA, to be specified (2 systems: either (1) momentary value and integrated or (2) moving average value) • Contact input/output • RS-232C (option)

Ambient temperature: 5-40 °C

Power: 100/110/115/120/220/230/240 VAC, 50/60 Hz (to be specified)

Dimensions: 430(W)×550(D)×221(H) mm

Mass: Approx. 15 kg.

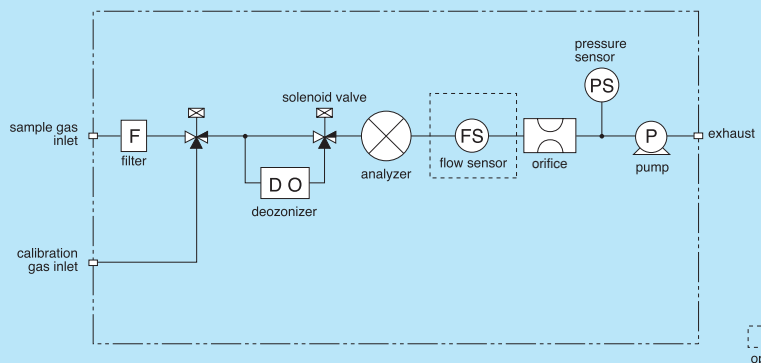

H₂S/TRS Measurement

Features • Principle

Combined use of the H₂S converter unit and the APSA: SO₂ Monitor makes H₂S measurement possible. The H₂S converter unit contains two types of catalyst: SO_x scrubber and H₂S converter. SO_x is removed by the SO_x scrubber, and then the H₂S that has passed through is converted into SO₂ by the H₂S converter. This SO₂ is then measured by the APSA: SO₂ Monitor for display as H₂S concentration.

Specifications

Range: 0.1-0.1/0.2/0.5/1.0 ppm

Power: 100/110/115/120/220/230/240 VAC, 50/60 Hz

Dimensions: CU-1: 430(W)×550(D)×221(H) mm
APSA: 430(W)×550(D)×221(H) mm

Mass: CU-1: Approx. 10 kg
APSA: Approx. 25 kg

Calibration Equipment

HORIBA offers various calibration products for optional use with the AP-370. HORIBA's calibration equipment support mainly the following methods:

Option	APMA	APSA	APNA	APHA	APOA
Internal or external permeation device for SO ₂ , H ₂ S, BTX, NO ₂ and many more		●	●		
External gas phase titration for NO/NO ₂			●		
Ozone generation with an internal or external O ₃ generator based on UV radiation					●

All calibrators can be equipped with thermal mass flow controllers or pressure regulators and capillaries depending on the precision requirements. Stationary and portable single components as well as multi-component calibrators are available upon client's specification. Corresponding interfaces as well as calibration and QC protocols can also be supplied.

NH₃ Measurement

Features • Principle

Combined use of the NH₃ converter unit and the APNA: NO_x Monitor makes NH₃ measurement possible. The NH₃ converter unit contains two types of catalyst tubes: one which converts NH₃ into NO_x, and one which allows the NO_x in the ambient air to pass through directly. The difference in NO_x value between the two is measured by the APNA: NO_x Monitor for display as NH₃ concentration.

Specifications

Range: 0-1/2/5-10 ppm

Power: 100/110/115/120/220/230/240 VAC, 50/60 Hz

Dimensions: CU-2: 430(W)×550(D)×310(H) mm
APNA: 430(W)×550(D)×221(H) mm

Mass: CU-2: Approx. 20 kg
APNA: Approx. 26 kg

Digital Calibrator

Features

HORIBA's MCC-1000 is designed to calibrate gas analyzers manually, remotely controlled or automatically, installed in air pollution monitoring stations, for quality assurance in the laboratory and also for the production of gas analyzers.

A special feature of HORIBA's MCC-1000 is the easily-to-read touch screen panel, for ease of operation. Characteristic of operation of HORIBA's MCC-1000 is the intuitive, simple and user friendly menu. (Flow rate, mg/m³, ppb/ppm, automatic cycles etc.) Via the touch screen, it is possible to enter span gas concentrations or to start automatic routines like multi point calibration cycles.

Specifications

Principle: Dynamic generation of zero and span gas with mass flow controllers

Mass Flow Controller (MFC): supports multi-point calibration

Power: 230 VAC ±10%, 50 Hz (other on request), 50 VA

Dimensions: 430(W)×400(D)×120(H) mm (19") with brackets

Mass: Approx. 10 kg

Intelligent Data Acquisition System

HORIBA IDA-2000

HORIBA's IDA-2000 is an intelligent data acquisition system (DAS) using a desktop or industrial PC, designed for fully automatic monitoring stations. The entire data capture and mean value calculation as well as control of the analyzers is executed by 32 bit multitasking software, running in a state-of-the-art Windows® environment. It combines the power of a workstation with the ease of use, compatibility and productivity of a personal computer. The measured values as well as operating and error status messages are gathered in a 5-second interval from the analyzers. They are converted into engineering units, checked for plausibility and synchronously converted into two different averages. Automatic calibration routines in predefined intervals can be started either from the station computer or through a remote host computer. The DAS also supports the manual execution of calibration sequences as well as remote maintenance operations.

Windows is a registered trademark of Microsoft Corporation in the United States and other countries.

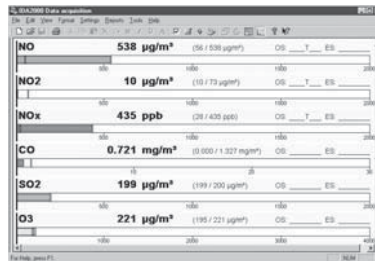

Bar graph of actual values

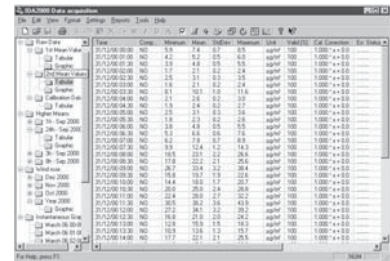

Tabular report of 2nd mean values

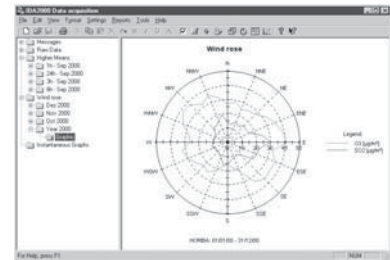
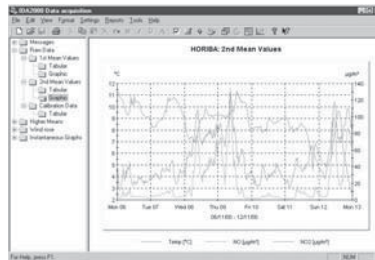

Data Management and Reporting Software

HORIBA IDA-ZRW

HORIBA's IDA-ZRW is a data management and reporting software for use in Ambient Air Quality and Meteorological monitoring. The software package provides data collection, management, analysis and reporting. Measured data and related information is stored in a high-end relational SQL database. The software can be used stand-alone or run on several machines in a network environment operating in Microsoft Windows environments. Communication between Central & Remote Stations works with a wide variety of communication links, such as direct connections, short-haul modems, telephone (including cellular) and multi-drop. Data can be transferred to and presented in Internet pages according to customers requirements.

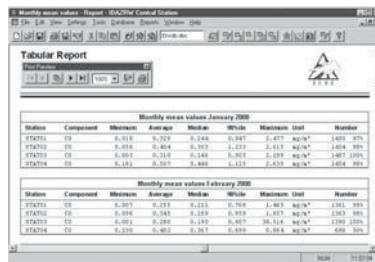

Report preview

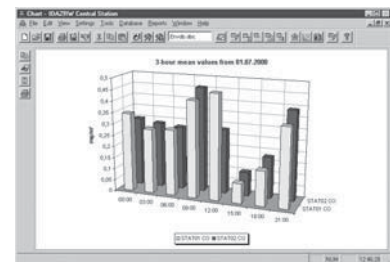

3D-column chart of 3h-means

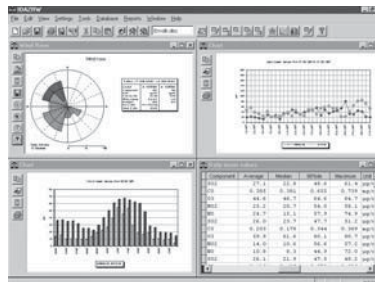

Example of various reports

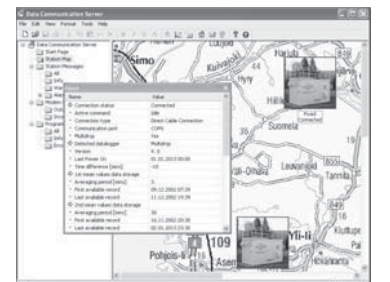

DCS main

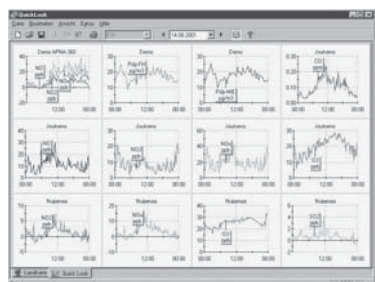

Quick look



Quick look

Complete Integrated System

HORIBA designs, assembles, calibrates and tests complete integrated systems for simultaneously measuring multiple pollutants. A system for monitoring five pollutants can typically fit into one 19-inch rack. Rack-mounted systems can be installed in equipment rooms, stand-alone shelters, trailers, vans, large trucks, or aboard marine vessels. HORIBA can integrate products into existing monitoring systems, or design and build a new system.



South african bureau of standards

Various Types of Fixed Stations and Mobile Laboratories

HORIBA designs and builds complete solutions precisely tailored to customer's requirements

● Fixed monitoring stations for continuously measuring air pollutants



Reykjavik environment / Iceland



Agency for environmental Federal State of Bavaria
Mobile laboratory with detachable shelter

● Mobile laboratories to investigate the geographic distribution of air pollution



Professional association for civil engineering



These vans and trucks are just some of the projects we've done for customers in Europe

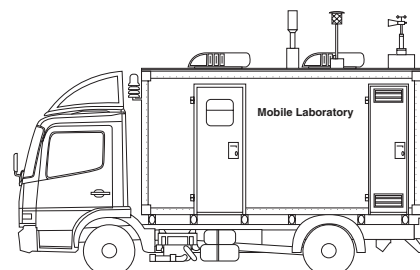

Standard 19-inch Packages

Each HORIBA AP-370 Series Monitor is packaged in a light metal enclosure with sliding chassis suitable for either a table-top set-up in a research laboratory or mounting on a standard 19-inch rack for permanent installation. All the controls and serviceable components are accessible from the front for easy maintenance while the plumbing and cable connections are neatly arranged at the back.

■ Dimensional Outline Unit: mm

APMA-370/APSA-370/APNA-370/APHA-370/APOA-370

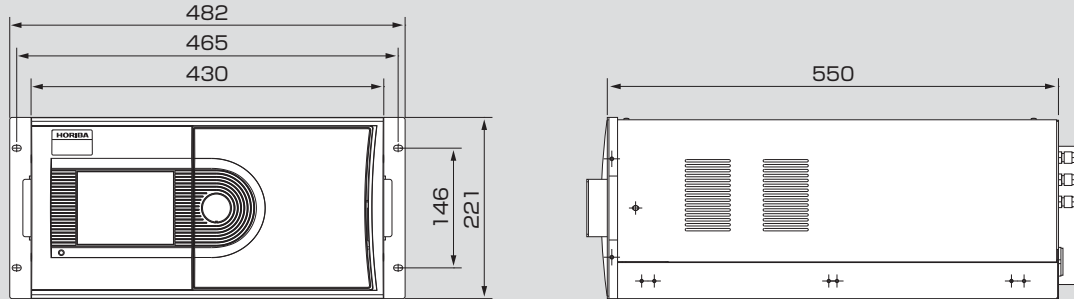

The HORIBA Group adopts IMS (Integrated Management System) which integrates Quality Management System ISO9001, Environmental Management System ISO14001, and Occupational Health and Safety Management System OHSAS18001. We have now integrated Business Continuity Management System ISO22301 in order to provide our products and services in a stable manner, even in emergencies.



Please read the operation manual before using this product to assure safe and proper handling of the product.

- The specifications, appearance or other aspects of products in this catalog are subject to change without notice.
- Please contact us with enquiries concerning further details on the products in this catalog.
- The color of the actual products may differ from the color pictured in this catalog due to printing limitations.
- It is strictly forbidden to copy the content of this catalog in part or in full.
- The screen displays shown on products in this catalog have been inserted into the photographs through compositing.
- All brand names, product names and service names in this catalog are trademarks or registered trademarks of their respective companies.

<http://www.horiba.com> e-mail: info@horiba.co.jp

HORIBA, Ltd. Japan

Head Office
2 Miyahogashi, Kisshoin, Minami-ku, Kyoto, Japan
Phone: 81 (75) 313-8121 Fax: 81 (75) 321-5725

HORIBA (China) Trading Co., Ltd. China

Shanghai
Unit D, 1F, Building A, Synnex International Park, 1068 West Tianshan Road, Shanghai, 200335, China
Phone: 86 (21) 6289-6060 Fax: 86 (21) 6289-5553
Beijing
12F, Metropolis Tower, No.2, Haidian Dong 3 Street, Beijing, 100080, China
Phone: 86 (10) 8567-9966 Fax: 86 (10) 8567-9066

HORIBA Korea Ltd. Korea

10, Dogok-Ro, 6-Gil, Gangnam-Gu, Seoul-Si, 06259, Korea
Phone: 82 (2) 753-7911 Fax: 82 (2) 756-4972

HORIBA Instruments (Singapore) Pte Ltd. Singapore

3 Changi Business Park Vista #01-01 Akzonobel House, Singapore 486051
Phone: 65 (6) 745-8300 Fax: 65 (6) 745-8155

HORIBA Vietnam Co., Ltd. Vietnam

Unit 10, 4 Floor, CMC tower, Duy Tan Street, Dich Vong Hau Ward, Cau Giay District, Hanoi, Vietnam
Phone: 84 (4) 3795-8552 Fax: 84 (4) 3795-8553

HORIBA (Thailand) Ltd. Thailand

East Office
850 / 7 Soi Lat Krabang 30 / 5, Lat Krabang Road, Lat Krabang, Bangkok 10520, Thailand
Phone: 66 (0) 2734 4434 Fax: 66 (0) 2734 4438

PT HORIBA Indonesia Indonesia

Jl. Jalur Sutera Blok 20A, No.16-17, Kel. Kunciran, Kec. Pinang Tangerang-15144, Indonesia
Phone: 62 (21) 3044-8525 Fax: 62 (21) 3044-8521

HORIBA India Private Limited India

Delhi
246, Okhla Industrial Estate, Phase 3 New Delhi-110020, India
Phone: 91 (11) 4646-5000 Fax: 91 (11) 4646-5020

Pune
502, 5th Floor, Purushottam Plaza, Baner Road, Baner, Pune-411045 India
Phone: 91 (20) 4076-6000 Fax: 91 (20) 4076-6010

Bangalore
Kamadhenu, No.17 / 1 - 32, Bannerghatta Road, Audugodi Bangalore-560030 India
Phone: 91 (80) 22210071

HORIBA Instruments Inc. USA

Head Office
9755 Research Drive, Irvine, CA 92618, U.S.A.
Phone: 1 (949) 250-4811 Fax: 1 (949) 250-0924
Alvin, TX
5318 W.FM517 Rd, Alvin, TX 77511, U.S.A.
Phone: 1 (281) 482-4334 Fax: 1 (281) 614-0303

HORIBA Instruments Brazil, Ltda. Brazil

Head Office
Rua:Presbitero Plinio Alves de Souza, 645, Loteamento Polo Multivias Barirro Medeiros-Jundiai Sao Paulo CEP 13.212-181 Brazil
Phone: 55 (11) 2923-5400 Fax: 55 (11) 2923-5490

HORIBA France Sarl France

12. Av des Tropiques Hightec Sud, F-91955 Les Ulis, France
Phone: 33 (1) 69-29-96-23 Fax: 33 (1) 69-29-95-77

HORIBA UK Limited UK

Northampton
Kyoto Close Moulton Park, Northampton NN3 6FL, UK
Phone: 44 (1604) 542-500 Fax: 44 (1604) 542-699

HORIBA Europe GmbH Germany

Head Office
Hans-Mess-Str.6 D-61440 Oberursel Germany
Phone: 49 (6172) 1396-0 Fax: 49 (6172) 1373-85
Leichlingen
Julius-kronenberg Str.9 D-42799 Leichlingen Germany
Phone: 49 (2175) 8978-0 Fax: 49 (2175) 8978-50

HORIBA Czech Czech

Prumyslova 1306 / 7, CZ-10200, Praha 10, Czech Republic
Phone: 420 (2) 460-392-65

HORIBA (Austria) GmbH Austria

Kaplanstrasse 5 A-3430 Tulln, Austria
Phone: 43 (2272) 65225 Fax: 43 (2272) 65230